

SPECIFICATIONS

MODEL NUMBER	POWER	BORE	STROKE	ROD	RAM SPEED		CAPACITY (TONS)	WEIGHT (LBS.)	SHIPPING DIMENSIONS		
					PRESS	RETURN			L	W	H
RTP-100	10 HP 3 Phase	9"	16"	4.0"	19 IPM	24 IPM	100	5,000	68"	80"	100"

Standard voltages available - please specify when ordering.
10 HP 230 1 phase available.

ROLL-IN TABLE PRESS 100 Ton

STANDARD FEATURES

- ✓ **Powered movable table** for ease of loading & positioning workpiece under cylinder.
- ✓ **Powered movable workhead** for off-center work allows operator to position the cylinder from left to right with the touch of a lever.
- ✓ **Hydraulic power-lift** for vertical displacement of head assembly.
- ✓ **Cylinder activation** is fingertip controlled, the more the hand lever is engaged the more the ram movement is accelerated. This allows the operator to control the proper speed for the task.
- ✓ **Pressure regulator** to limit the ram pressure.

AVAILABLE OPTIONS

- VB-100** V BLOCKS matched pair.
- FSG-100** Front safety guard for operator protection.
- SSE-100** Stop / Start c/w emergency stop button, wired direct to motor.
- PP-100** Pressing Plate

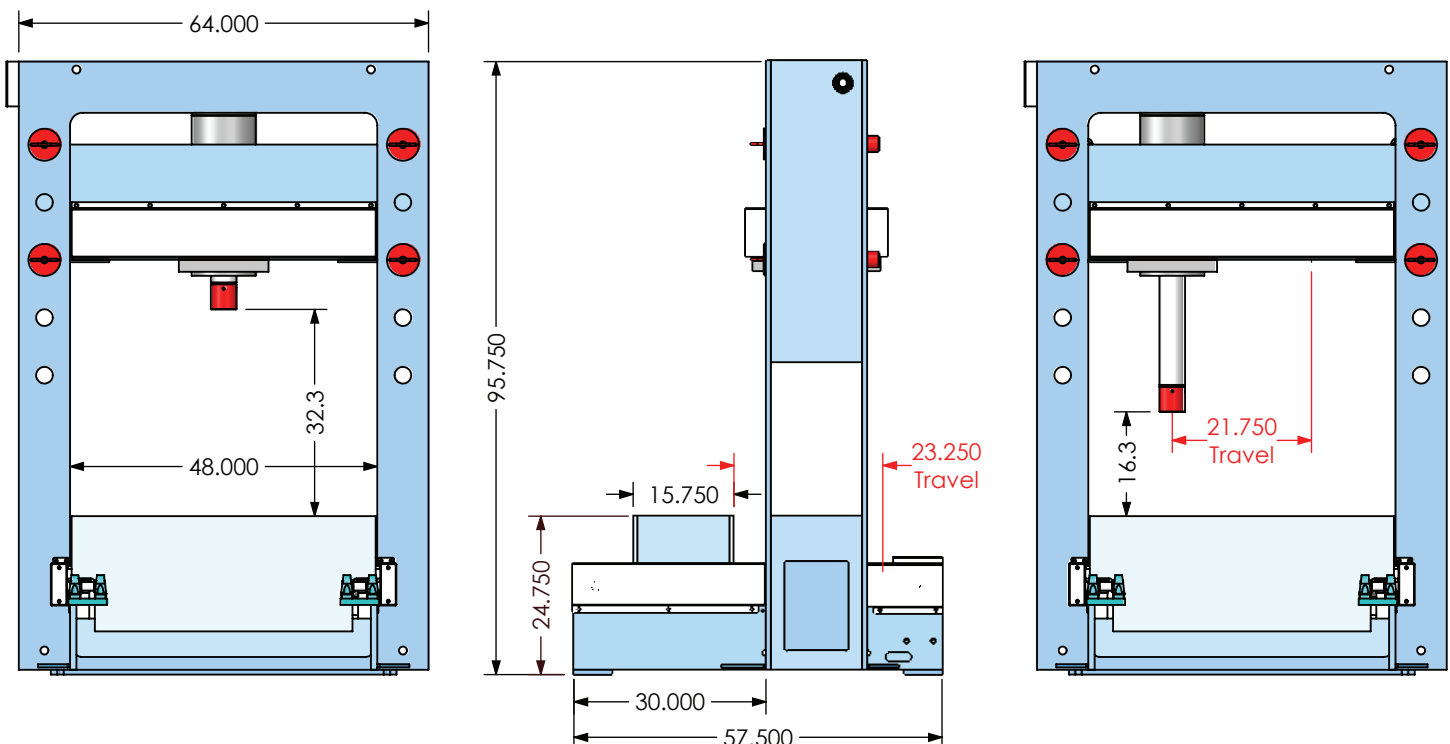

Custom designs available
We Build Them your Way!

RTP - 100
ROLL-IN TABLE PRESS 100 TON

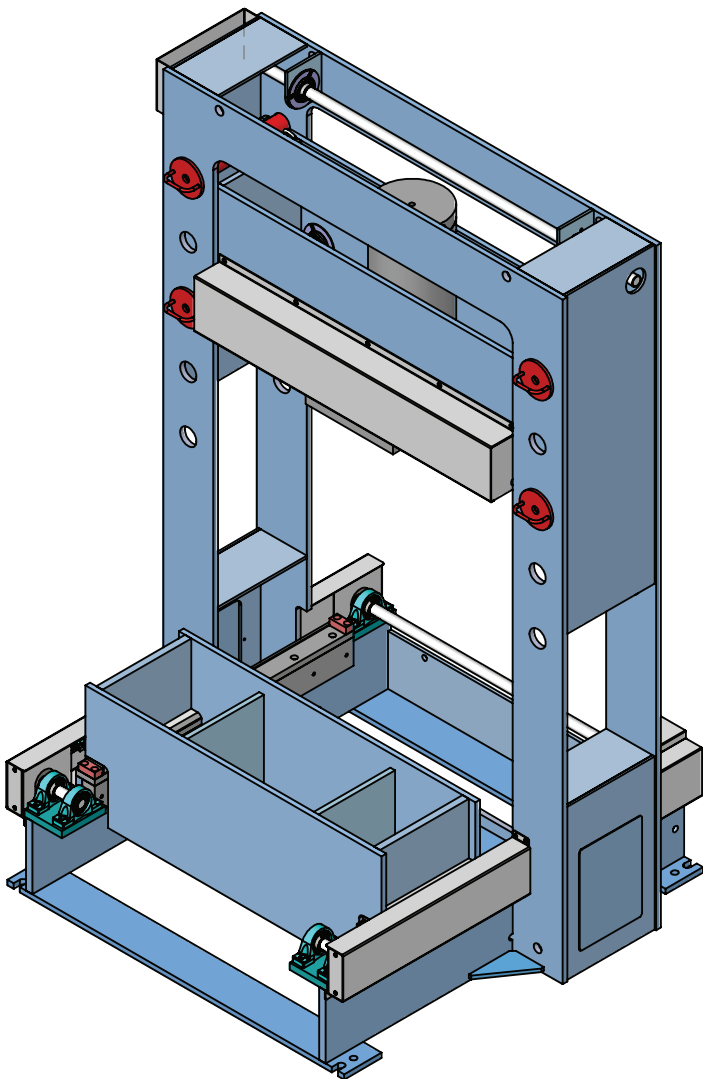

Front View

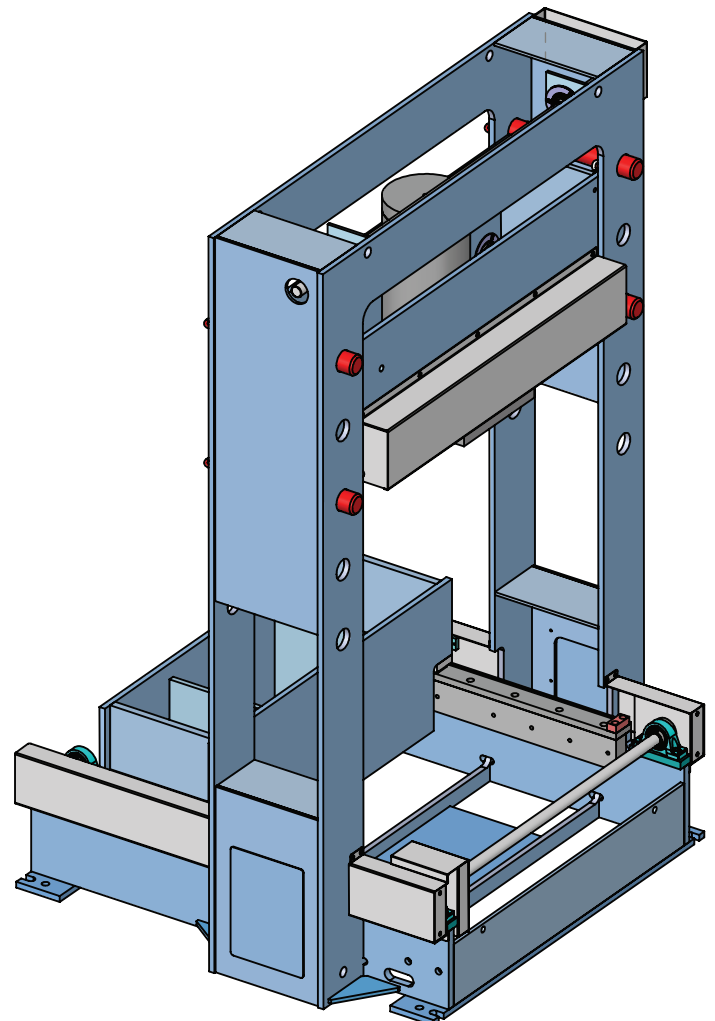

Back View